

# THE OLD VARIETY STORE

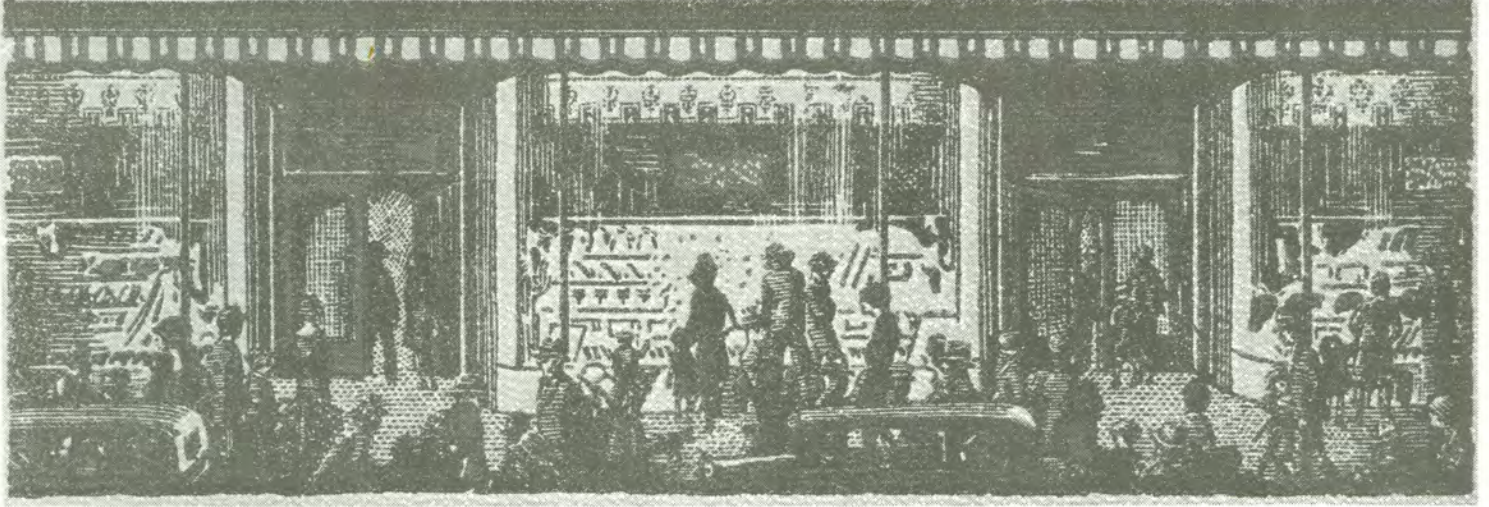

OCT. 15, 1987

\$3.00

#3

*FUN COLLECTIBLES FOR GROWN-UPS AND KIDS*



## GETAWAY CHASE GAME



# NEWS From The Storekeeper



Hello again and welcome to the "new improved" Old Variety Store! Those who are joining us for the first time may wonder what I am talking about; those who have been with us are wondering what happened to our former title - "The Toy Candy Container and Food Premium Collector". The reason for dropping the old title is because it was just too long - hardly anyone had the time to say or write it! The Old Variety Store was chosen to convey our emphasis on the less expensive "variety" of collectibles (that you very well may have purchased at one time from a variety store, country store, or from a premium ad, etc.). Also, it's fun to read about the many, many varieties of collectibles that can usually be found at bargain prices. But don't be too quick to peg us into a hole! We have lots of surprises ahead. And just as every old variety store may have had a few "prize" items such as a soda machine out front or a fabulous display piece in the window, we won't leave these out if you readers want to write about them. The important thing to remember is The Old Variety Store is a nostalgic "feeling" giving title. The emphasis is not on old variety stores (per se), but on collectibles and memories associated with "small business's" if you will, which hold particular strong memories for millions of people.

There has been a tremendously favorable response to Premium Watch. And with good reason. Premium offers are usually good for only about a year or less. (In McDonald's you only have about a week if you want the contents from a particular Happy Meal!) The better ones feature a character or advertising item not available in any stores. The general public, having sent for them, usually keep them as souvenirs or hands them to children, hence increasing the premiums scarcity. No matter what you collect, there are current product premiums that will usually tie in with your collection, not to mention those particular premiums that seem to reach out, grab you, and say, "send for me!". And most of the time they are free or cost very little. The manufacturer just wants you to buy more of their product. But Premium Watch also needs your help. We don't see all the premium notices so please send us what you find and we will add it to each Premium Watch and give you the thanks. We will not repeat the same item in the next issue so try to get the premiums that interest you when you see them. Because sweepstakes, discount coupons on the same product, and free food samples are not really premiums, generally these will not go into Premium Watch. What do you do if you see premiums in Premium Watch and you do not have the notices by which to send for them? If you have been unable to contact the company (some companies have an 800 number on the packaging), send us a self addressed stamped envelope and .15¢ per premium notice you need and we will send you a photo copy if we have it. We'll refund the .15¢ per photo copy cost if we do not have it. We are doing this as a service to our readers and because we need those premium notices sent to us.

In closing I would remind the readers that if they have a question and need a response from me, please enclose a SASE because the postage really adds up. If you write a little note and omit a SASE, you may not hear from me at all or until I can enclose a note in your next issue. There is no need for a SASE if you are contributing in some way to the magazine. Please drop a line to those who wrote articles if you particularly enjoyed what they had to say or can help them with their collection. We encourage letters to the editor along the same lines, but if you wish to request information or need help with your collection, an article or a classified ad is the appropriate place for that. We will not print street addresses in the letter to the editor section. GOOD IDEAS and especially ARTICLES are always wanted!

Steve Powers



# LETTERS

The Old Variety Store Post Office

Steve -

I Received my second issue today and just can't put it down! I know that everybody must tell you how they remember all the premiums that you write about. I know that I do!!

I saved some stuff from years ago. I still enjoy sending for and collecting premiums. I guess it's because usually you can get a prize for a little bit or nothing! The word "FREE" appeals to me almost like it's a disease! I know that collecting premiums is certainly infectious!!

I am enclosing some current information that perhaps you can use in "Premium Watch". I enjoyed getting new ideas on where to look for stuff!

Keep up the good work! I can see the guide only improving as more and more collectors get involved!!

Yours eating cold cereal morning, noon & night!

- Karen Ripple, Sturgis, MI

(Thanks Karen! Your letter made my day. It's readers like you that make this publication work. We appreciate the premium notices you sent us because by far we don't see them all in our locale. The "regional only" premium offers such as you sent are especially intriguing as collectibles because they are limited to only one or just a few states. Readers can probably guess what products these are in Premium Watch if they have never heard of them! - ed.)

Dear Steve,

There are a number of comments I want to make concerning your new publication. First, I think it is an excellent idea & it fills a much-needed spot in the world of various memorabilia collecting. I think that the "Premium Watch" that you came up with is a GREAT idea, & will prove to be a major selling point in starting, & renewing subscriptions & single-issue sales. I realize that this publication is just starting out & there are many things you probably want to do with it once you get sufficient subscribers, advertisers, and article submissions. IF possible, based on the 3 just mentioned areas, it would be great if you could go to monthly format. I know this would be a lot of work & you would have to work out new subscription rates, etc. This may well not be practical, but at least consider it, you might be pleasantly surprised at how well that would go over, not to mention in helping the timeliness of your "Premium Watch" & collector ads. Also, once you get rolling & have sufficient article submissions & paid advertising, hopefully the (magazine) will become thicker.

(cont.) Although I do not collect PEZ items or Pirate items (ref.: "Pirate Potpourri" issue #2), I still enjoy reading about them & other oddball items. (Don't take that the wrong way. I know that these are not "oddball" to you, just as 3-D premium collecting is not "oddball" to me. What? You mean EVERYONE doesn't collect PEZ & Pirates & 3-D???? What's wrong with those people?) As you said in your editorial, it's not "the same old thing", and even if I don't collect a certain item it's nice to read about other "fun" things. By the way, I'm 39 years old (REALLY 39) (!) & as a child growing up in the 50's, one of my clearest memories is that of getting the Ideal Pirate Ship (pictured in issue #2) for either my birthday or Christmas, and playing with it in the bathtub! I remember that it also had very small recessed wheels on the bottom so it could be rolled on the floor as well as floated in water. One other reason I remember it so well as that I was disappointed that the plastic men did not float, but sunk to the bottom of the bath tub!! They were made out of a different type of plastic than the usual toy soldiers & Marx playset figures were made of. Stupid reason to be disappointed, but for an 8 or 9 year old boy, it was upsetting. I also remember how popular PEZ dispensers were back in the 50's. My friends & I ALWAYS carried one around in our pockets & at every corner candy store we'd try & find new flavors to buy for it. I don't know how old you are (29. REALLY 29! -ed.), but believe me, PEZ was at least as popular & the "in" thing then, as Garbage Pail Kids cards are now. I remember that the first ones we were ever aware of had just "plain" tops & were that way for several years. I THINK, but am not sure, that either Superman or Howdy Doody were the first of the character tops & how surprised we were to see them. We collected some of them although I don't remember specifics, but I do remember that we weren't real happy with them because they were awkward & didn't fit nicely into our pockets like the original slim-top ones did! You are probably tired of my rambling, so I will close. I think you are doing a great job on this & can't wait to see it grow.

- Greg Anglin, Liverpool, NY

(That isn't rambling, Greg - That's poetry to my ears! I love to hear those childhood memories and I know our readers do to. In fact, I think that some people faced with the challenge of writing an article are sometimes hung up about it if they can't remember specific dates or have a ton of research to share. Sure, everybody likes information, but when you get right down to it, it's the "human interest" that oftens warms our hearts and what we may ultimately remember about something

(cont. on next page)



Letters cont.

(along with those tricky "values" when they are mentioned!) I would encourage our readers to share similar memories with us either by way of a letter to the editor or in an article combined with as much information as they know with some clear pictures. Pictures are helpful, but they are not always necessary. Old radio shows enthralled millions of people without pictures. It's called story telling. I'd also strongly encourage articles submitted to The Old Variety Store that are not necessarily "collectible" related in every case. For instance, historical articles about places such as old amusement parks, children's zoos, carnivals, picture shows, playgrounds, barn yards, gas stations, country stores, toy shops, hobby shops, soda fountains, candy shops (to name a few) - even the place of your first (or most interesting) job, be it from a news paper stand in a train station to a fast food restaurant. (Mine was! In down town San Francisco in one of the now folded chain of A & W Root-beer restaurants.) In some cases these places have been torn down or turned into something else. But should we forget them? Never! We are talking about chronicling in some ways a disappearing part of our culture which holds very fond memories for millions of people because of the strong associations with family, childhood, good times and outings. This should be a magazine the whole family can enjoy. I remember subscribing to a magazine as a pre-teen called The Good Old Days, which is exactly what it was about though some will argue the point because of the depression, poor medicine, etc. While I've always liked nostalgia, you can see that even young people are interested in the lives and times of their parents and grandparents. Where visually we may have no souveneers of these places to share, we may be able to find pictures of them on old postcards or by visiting our local historical societies.

Concerning the two PEZ you mentioned, for the sake of our readers who would love to get a hold of a Superman or Howdy Doody (we would too!), there is no knowledge among collectors at this time that either of these exist, which is not to say they don't. So far no one has one. Again I must mention that the PEZ company kept no records. It's up to us to publish whatever information about PEZ that comes to light, but thank you for that wonderful memory of PEZ in the 1950's. I have two "slim top" PEZ dispensers like you mentioned. One is quite early as it was made in U. S. Zone Germany, and the other is a special PEZ premium I believe offered in the 1960's and early 70's called the "Golden Glow" dispenser.

Regarding my Pirate article, the 1950's Ideal Pirate Ship is a very difficult to obtain toy nowadays, especially complete with all "sinkable" figures and accessories which included a little life boat and oars! Maybe that's why I don't have one. I borrowed one from a friend for the pictures. I also learned that the Capt. Hook figure was not a cereal premium, but

from a Marx playset (says one source).

Greg, you hit the nail on the head concerning our adding additional issues. Advertising and additional subscriptions are necessary to finance more issues and pages per issue. (I'm adding my own mail order business to off-set costs.) I want to see more articles and content and obviously the subscribers to do, but cliché as it sounds, remember, "Rome wasn't built in a day"; neither did the first F. W. Woolworth Store back in 1879 develop into a chain overnight. The fact that we're not "big potatoes" now doesn't mean we won't be. I do appreciate your suggestions and of course I realize they are not at all criticisms. I print them because I know this is on the minds of others and it's only fair for me to reply. This also gives me an opportunity to get my message across for more advertising and additional distribution opportunities across the U. S. and Canada. (Bulk rate for 5 or more copies available for those wishing to sell The Old Variety Store for profit in their store or antique collective booth. Write for details.) Also, to go monthly at this time would require the additional revenue to pay for a small staff, even if it was just one other person. The amount of time involved in each issue is unbelievable! However, I can't tell you how enthusiastic I am about The Old Variety Store! Ideas for it bombard me constantly, some of which will eventually make it into the pages. Contests, articles, features, places to visit and write about, premium watching - it's tremendous! And how helpful it is when people like you, Maryann Kennedy, and Judy Wehner send in such good articles as in this issue. The less expensive "variety" items are the coming thing in collectibles! Antiques have become too high priced. Forget 'em! There are bargains galore even in antique shops and shows because a significant amount of dealers are not tuned into them or right now there are not droves of collectors for these items in every state. I've been at toy show set-ups where someone will unpack their cast iron toys (costing hundreds of dollars each!) and 15 or 20 men will run over and try to purchase whatever they can before the next guy. At the same set-up's I've leisurely wandered around asking for PEZ, candy boxes, or other "small potatoes" items which I know are worth more than hardly anyone is looking at. They are not that easy to find, I'll guarantee you that. But at least when you do you won't be mowed down by 15 or 20 other collectors at the same time with their pockets stuffed with more cash than you make in a month!

Back to advertising. (I know you'll be seeing more in our pages than at present.) I can understand how some advertisers may be reluctant to "break the ice" and advertise in The Old Variety Store since they figure we're new, why take the chance (it's not like were so expensive!), etc. But we already have a large, growing, and very enthusiastic subscription base who are targeted in to what we specialize in and probably collect much more than that. I might add (and this is perfectly true) that some new magazines appear to have "tons of ads" because they have solicited them with offers of free display space to key "names" in



Letters cont.

the collecting fields (whether they ever subscribe or not) without the paying readers being any the wiser. Since this may mislead readers into subscribing based on "big ads" rather than article content and features, I have not adapted this practice for ethical reasons. This magazine will stand or fall on its own merit. While unquestionably appreciated and necessary for growth, I feel advertising is a secondary issue next to article content and stories. Because we do appreciate our subscribers, we offer a free one time 30 word classified ad as our way of saying thank you. A 1/6 page display ad or up to 100 free classified words is offered as payment to those who go to the trouble of writing us an article of one page or more which we use; 50 words for a half page article, etc. Advertising space or collectors items will go to the winners of upcoming contests as well. But I do hope you and our readers see my point in all this. We our more than doubling in subscribers with each new issue and I am optimistic about the future of The Old Variety Store, given the fact that this is only our third issue and the first with the new title.

Well, maybe I'm the one who needs to stop rambling now! I've responded at length because we're still "under development" and can afford a little introspection. Later such matters will not require a public answer which you, Greg, perhaps were not expecting anyway. Thank you Greg and all our subscribers for your support and the many nice comments we've received! Our aim is to make The Old Variety Store the best we can! - ed.)

## KIDS CORNER



JASON WILCOXEN'S

PEZ COLLECTION (and dad's too!)

Way to go Jason!  
Nice PEZ store display!

**OKAY FOLKS! IT'S TIME YOU SAW A DISPLAY AD SO HERE IS AN, AHM, EXAMPLE!**

**WANTED! PEZ !! ANYTHING PEZ!**

There are still dozens of dispensers yet to add to my collection (plus variations) so please tell me what you find. Cash or trade, including some wonderful PEZ duplicates such as the full figure Santa dispenser, a 1950's rotating tin counter rack (for candy packs only), a U. S. Zone Germany tin clicker, and several dispensers including these four "soft heads" - Wonder Woman, Batman, Batgirl, and Penguin. Please keep an eye out for PEZ advertising pieces such as the Donkey Kong, Jr. cereal box (and dispenser premium), the Cocoa Marsh premium offer package and dispenser, and the Stand By Me video store premium.

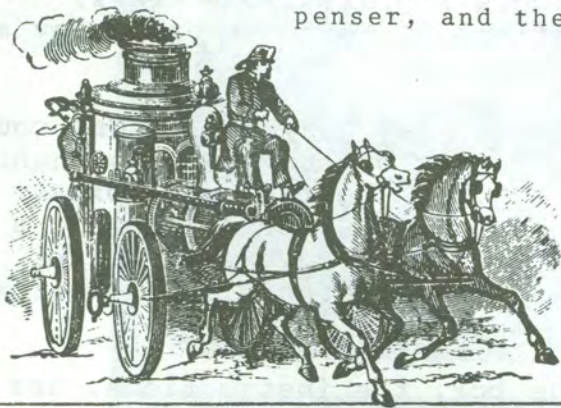

Also wanted: Pirate figure and ship plastic model kits, candy boxes, cardboard toys such as the Mobile Tank and Polaris Nuclear Sub, battery operated JUNGLE HUNT GAME, and any recordings of singing cowboy Red Harper!

Steve Powers, 121 Codo St., Moss Beach, CA, 94038 (415) 728-5851



# GETAWAY CHASE GAME

A SUNRAY DX OIL COMPANY PREMIUM

by Steve Powers

Getaway Chase Game by AMF is a unique and exciting toy. My older brother Mark received one on his 12th birthday 20 years ago this month in 1967. The box claims it as "the toy of the year". That may have been true because we loved it and must have played with it until it wore out.

I can't tell you anything about the Sunray DX Oil Co. because Mark received his game in a different box than the Sunray box pictured. It looks to me like it was both a premium and a toy store or catalog toy.

A couple of years ago I started hunting down some of the favorite toys I remembered from my youth. Getaway Chase Game was one of them and it happened that when I finally found one it was in this special Sunray DX Oil Co. box. Other than the possible addition of a little Sunray gas station (my set is missing the building at the side of the game as it appears on the box lid) and two little Sunray signs, the contents are exactly as I remember them. Two black battery driven slot cars careen around and around through a printed cardstock city and country scene. The cars really travel fast and the two players, each representing opposing sides of the law as represented through a police car and a gangster car, each have a switch box with which to make the cars change roads on the track. The police officer goes from rookie to chief and the gangster goes from petty thief to public enemy #1!

Other than that I'm sorry to say I can't specifically remember the rules of the game because my set is missing the instructions! My guess is it operated on the chase/evade/capture (or cut-off) principal and that is how one earned points and moved up in crime or law enforcement. The switch control units have peg holes to mark your progress.

The box measures 24½" x 20" and the set up plastic game board measures 38¼" x 24". The buildings are well detailed and have that 1920's and 30's look. In the city there is a bakery, hardware store, two apartment buildings, a department store, fire department, bank, and police station. The country area is made up of a store and gas station, feed and grain, mansion, hotel, estate, farm house, mill, and water tower. There are also some trees, fences, and signs to round out the colorful effect of this wonderful toy and game in one. They don't make 'em like they used to.

While not that easy to come across, this is a toy that many collectors could enjoy, from old country store and gas station collectors to The Untouchables collectors. Imagine a few old country store advertising tins and boxes, specifically from the roaring 20's, set up behind Getaway Chase Game in a display case and you have a nice miniature look at the days when Elliot Ness battled Al Capone, or when the G-Men chased after John Dillinger after a bank robbery.

I'd like to get the set in the different style box, the instructions, and anything else I am missing if anyone can help.



# GETAWAY CHASE GAME

ROOKIE    SERGEANT    LIEUTENANT    CAPTAIN    CHIEF

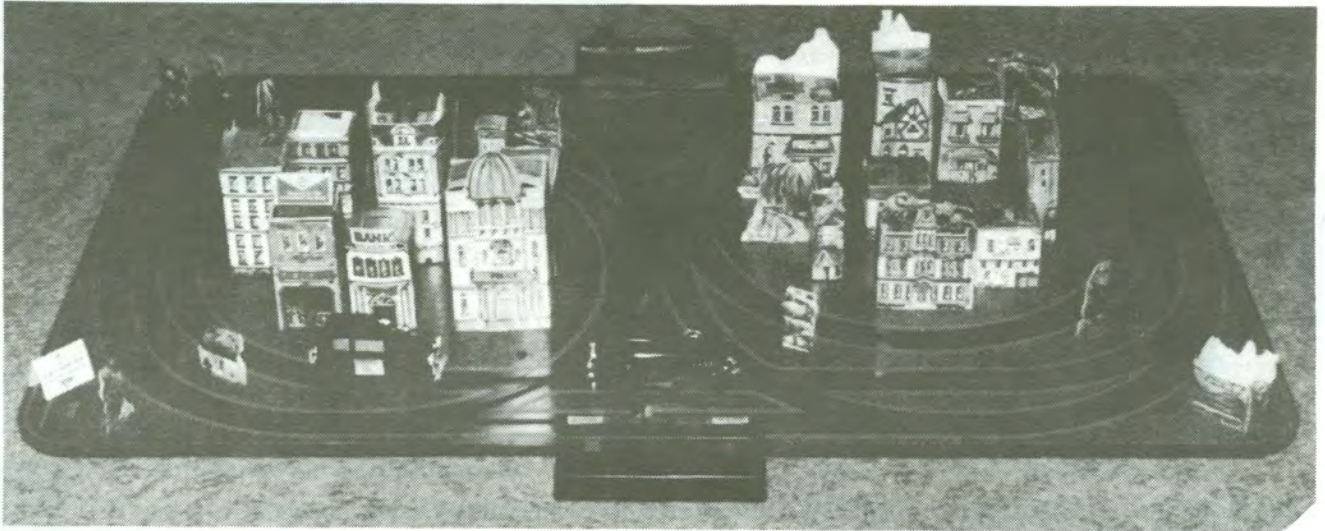

PETTY THIEF    SWINDLER    GUNMAN    MOBSTER    PUBLIC ENEMY NO. 1

**DX** **GETAWAY chase game**

TOY OF THE YEAR!    EXCITING ACTION GAME!    FUN FOR EVERYONE!



**41 PIECE GAME INCLUDES:**  
 2 BATTERY OPERATED CARS, 4 REMOTE CONTROL SWITCHES, 2 SWITCH CONSOLES, RUGGED PLASTIC GAME BOARD AND TRACK, 2-D CITY AND COUNTRY BUILDINGS, CAR CUSTOMIZING KIT (GAME USES 2 "C" BATTERIES—NOT INCLUDED).

© 1974 DX COMPANY  
 MADE IN U.S.A.  
 DULLES, VA. 20801

**DX**

**GETAWAY chase game**



**DX**

Known by the customers we keep



# H A L L O W E E N C A N D Y C O N T A I N E R S

by Judy Wehner

PEZ dispensers for Halloween are Monster (3rd Series), Skull (3rd Series), Jack-O-Lantern (2nd Series), Witch (3rd Series), and the same four (4th Series). This group of four is being sold in the same display box. The new PEZ dispensers are basically the same as the older ones with the addition of feet.

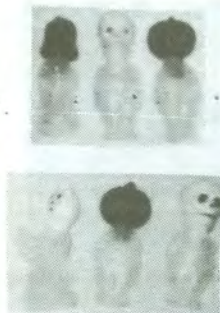
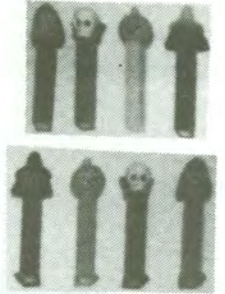

E. Rosen Company, Pawtucket, R.I. Ten or more years ago they made a Witch (with witch body) and Skull and Jack-O-Lantern (with man's suit and tie bodies). These contained small round candies much like the glass containers once held. The new containers are Ghost (ghost body), Jack-O-Lantern, and Skull (suit and tie bodies). The bodies of the new figures are very similar to the old, but the heads are considerably different. They are filled with candy-coated chocolate candy. The new containers have the name K-Mart and the price .58¢ printed on their labels.



E. Rosen Company also has a flat pumpkin filled with jelly beans.

Company unknown. The Skull and Witch containers come in many colors. I have found no mention of a company on the container or the display box. The Skull contains two packets of heart-shaped candy and a toy. The Witch contains one packet of small round candies and a toy. Some of the plastic toys are - comb, robot, spider ring, and pipe.



R. M. Palmer Company, West Reading, PA. There are four cardboard buildings - Haunted House, Dragon's Castle, Mummy's Tomb, and Creepy Corners Schoolhouse. They are filled with wrapped chocolate candy. There are also four cardboard coffins - Skeleton, Jack-O-Lantern, Monster, and Warewolf. The figures are chocolate covered with paper.



American Candy Manufacturing co., Selma, AL. There are four 13" to 13½" clear plastic tube containers with different heads and contents as follows: Jack-O-Lantern (ball gum), Witch (Indian corn), Devil (jelly beans), and Skull (candy corn).



E. J. Brach & Sons, Inc., Chicago, IL. Brach's also has a 14" clear plastic tube container called "Pumpkin Bank". It is filled with candy-coated chocolate called "Jots." It has a slot in the back of the head so it can be made into a bank when empty.

All of the above are available in the stores now with the exception of the four older PEZ dispensers and the three older figures by E. Rosen. None of the new containers are dated.





Figure 8

IT CAME FROM PEZ  
SPACE HEADQUARTERS!

By Steve Powers

You've got to hand it to the PEZ distributor of 1950's New York City for coming up with **PEZ SPACE HEADQUARTERS** - what a classic "premium sounding" address! And what a wonderful premium the 1950's PEZ Space Gun is! Though just a little thing at 3 3/4" tall, it is one of the most desirable and sought after PEZ items. Made in Austria, the raised illustrations on the handle of a rocket flying through space have that pre-days-of-space-travel look.

It appears to me that it was available only through the mail since I have an original mailing box (bulk rate paid in ?ford, Conn. Permit #273) and the instructions say, "Issued by PEZ Space Headquarters, 75 West Street, New York 6, N.Y." Amazingly I have this plastic candy dispensing gun in two colors, red and black. The outside part numbers 1, 2, 3, and 7 are white on both guns. Part #2 says, "MADE IN AUSTRIA PAT. PEND."

Now let's move on to another great PEZ candy dispenser, the 1950's full figure Robot. This fellow is about as hard to find as the Gun! It is known in the colors blue or red and possibly yellow. Made in Austria, "PEZ" is written in raised letters on the back. Some people call this an astronaut. I don't feel the dispute will be settled until someone comes up with the original packaging or a promo sheet. Now wouldn't that be a find!

After these two special PEZ space items, PEZ began to add "space men" or "astronauts" to their line. The space man with a clear helmet on the top of the stand in figure A (the stand is an early 1970's premium) is 1st Series and made in Austria. There is a very interesting variation of this space man (which I don't have) with the words "COCOA MARSH" in raised letters on the side of the dispenser. This cocoa company must have offered there own special advertising version of this space man probably in the 1960's. Cocoa Marsh is a product not known to me at all here in California which makes the PEZ/COCOA MARSH Space Man difficult to find in some parts of the country.

The two identical astronauts on the bottom of the stand in figure A are both 4th Series and made in Austria. One has a white helmet and one has a blue helmet - both have yellow face shields. I have seen a white helmet example without a patent number on the dispenser, just "Made in Austria". The same is found on other dispensers for an unexplained reason.





The other astronaut pictured in figure B standing alone is another one I don't have (picture courtesy of Maryann Kennedy). 1st Series, it has a gold helmet and face shield with the same face as the clear helmet or Cocoa Marsh space man. We do not know if there are other space figures at this time.

The large unusual PEZ Space Gun (figure C) you see pictured in a blister pack (front and back) is from the 1980's and the last non-regular dispenser item PEZ has made to date. The gun measures 8 1/2" long, came in the colors red or silver (12 in a case - 6 red, 6 silver), and with 6 packs of candy. It has a strong spring mechanism which shoots the candy with some force. Canadian collector Ross Hartsough has a wonderful promo sheet with super space graphics for this gun.

There is a fascinating story surrounding the 1980's PEZ Space Gun which may help to explain why you never see it in stores. The story goes that it was targeted as a bad idea for a toy on a nationally broadcast consumer show! The host apparently demonstrated how the gun was to be used - that the barrel of the gun is to be placed in the mouth and then the trigger pulled to release the candy. This was shown to be in very poor taste, especially in the 1980's with so many hand gun deaths and accidents. (Kids who don't know any better might try the same thing with a real gun. You can see how the host may have really shown disgust with the PEZ Space Gun.) This program instigated a quiet but immediate recall of all PEZ guns on store shelves across the nation.

Some of those who were keyed into this, such as distributors for PEZ, must have "kept" a few for themselves, recognizing the instant collector's item status. As such, a few of these guns have made their way into collections, ranging in price for between \$15.00 and \$25.00 a piece. They were most always obtained in mint, old store stock (or recalled!) condition.

Naturally the vast majority must have been sent back to PEZ for their disposal. I've always wondered what a company does under a situation like this. It is probable that they invested thousands and thousands of dollars in the gun tooling alone, let alone the packaging material and printing. Since this was a new product presumably there were vast holdings in warehouses awaiting further shipment. The candy could have been re-packaged. But what were they to do with all the guns? Were all these guns thrown into the incinerator?

I have recently learned of an interesting development. The exact same gun, minus "PEZ" on the handle and replaced with "DSH", has been found! This would be easy to do since the grip on the handle with the letters "PEZ" could be pried off and replaced with a new one. For the sake of factual reporting I do not know for certain which of these guns came first since I have not seen the DSH Space Gun. But this I do know - the DSH Space Gun shoots small plastic blocks shaped like none other than PEZ candy ! !

In retrospect, it does make one wonder how the PEZ dispenser designers could have developed the 1980's Space Gun for today's market (and if any corporate heads rolled!). Perhaps one of them had fond memories of the 1950's Space Gun. Too



Figure A



bad that this time around, a generation later, the idea didn't work. I for one certainly hope that this embarrassing set back for the PEZ company will not inhibit them from producing other creative novelty dispensers and collector's premiums in the future.

## GUN PERMIT

PEZ SPACE GUN  
FULLY AUTOMATIC

NAME: \_\_\_\_\_ ADDRESS: \_\_\_\_\_  
ISSUED BY PEZ SPACE HEADQUARTERS, 75 West Street, New York 6, N. Y.  
VALUABLE - SAVE THIS PERMIT!

### How to clean and assemble your PEZ Space Gun

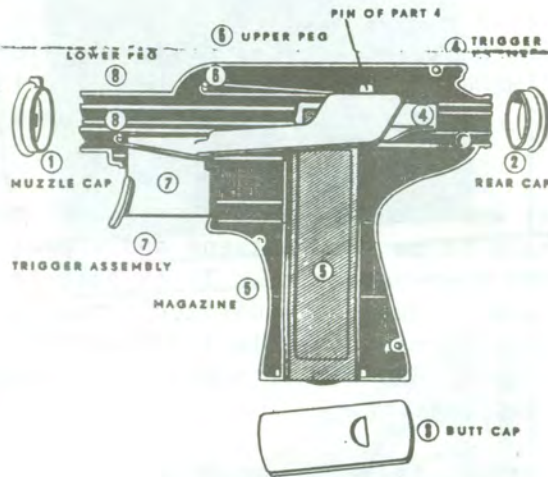

1. Place gun on table with trigger (part 7) pointing to the left.
2. Pull off parts 1 and 2, and slide off part 3.
3. Lift top cover off.
4. Remove all parts from gun, and blow out dust.
5. Replace part 4 in center channel with pin facing away from you, as shown. Hook large rubber band from pin of part 4 to part 6.
6. Replace part 7 in lower channel, as shown. Hold trigger down with forefinger. Replace cover.
7. Replace parts 1 and 2.
8. Replace magazine (see reverse side).

### How to load your PEZ Space Gun

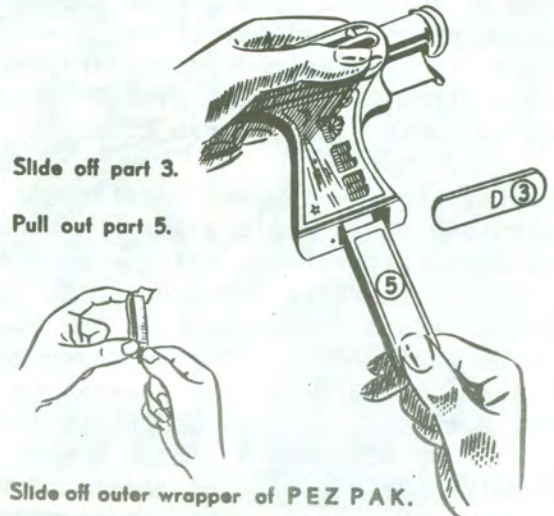

Slide off part 3.  
Pull out part 5.

Slide off outer wrapper of PEZ PAK.  
Hold PEZ PAK between forefinger and thumb. Fold back foil paper to show one half of PEZ bullets.

Hold PEZ PAK in one hand, pull out magazine tray with the other.



Place PEZ bullets into tray, slide tray back into magazine sleeve.

Replace filled magazine so that open end of PEZ bullets faces trigger.  
Replace butt cap 3.



PEZ-HAAS, INC.  
75 WEST STREET, NEW YORK 6, N. Y.



# McDONALD'S 3-D HAPPY MEALS

By Greg Anglin

In 1981 McDonald's produced a 3-D version of their popular "Happy Meal". The box consisted of a series of old-time photographs and new cartoons done in Anaglyph 3-D. The Anaglyph process is that of red/blue (or red/green) images slightly offset from one another. When a pair of cardboard 3-D glasses is worn, the red lens over the left eye, and the blue (green) lens over the right eye, the image converts into one of depth, in which it looks like you can literally reach "into" the picture.

There were four different versions of the 3-D Happy Meal produced, one for each of four consecutive weeks. 3-D glasses were included in each one (see below, folded flat), and these were very clever, being a pair of "Golden Arches" with a red and blue lens inserted. The photographs were converted from original STEREO photographs (as in the old-fashioned stereo viewers) from the Special Collections Dept. at the University of Missouri at Kansas City. The cartoons were the typical McDonald's type of children's riddles and puns: Q: Where do cows go on Saturday night? A: To the moo-vies! Yes, painful stuff, but we love these as collectibles.

Addressing the question of rarity, I have to say that while these are not extremely rare, they are VERY scarce. They are out there, but you have to be very patient and expect a lot of hunting for these, especially in assembling all four varieties. It is safe to say that you may NEVER obtain a complete set, and will have an extremely difficult time in finding even one. While fast-food collecting has grown tremendously in the last five years, there were relatively few collectors prior to this, and few of these would have survived children's hands or their mother's kitchen wastebasket.

Good luck on your search for these, and other, fast-food premiums!  
Greg Anglin, 7410 Farmstead Rd., Liverpool, N.Y. 13088

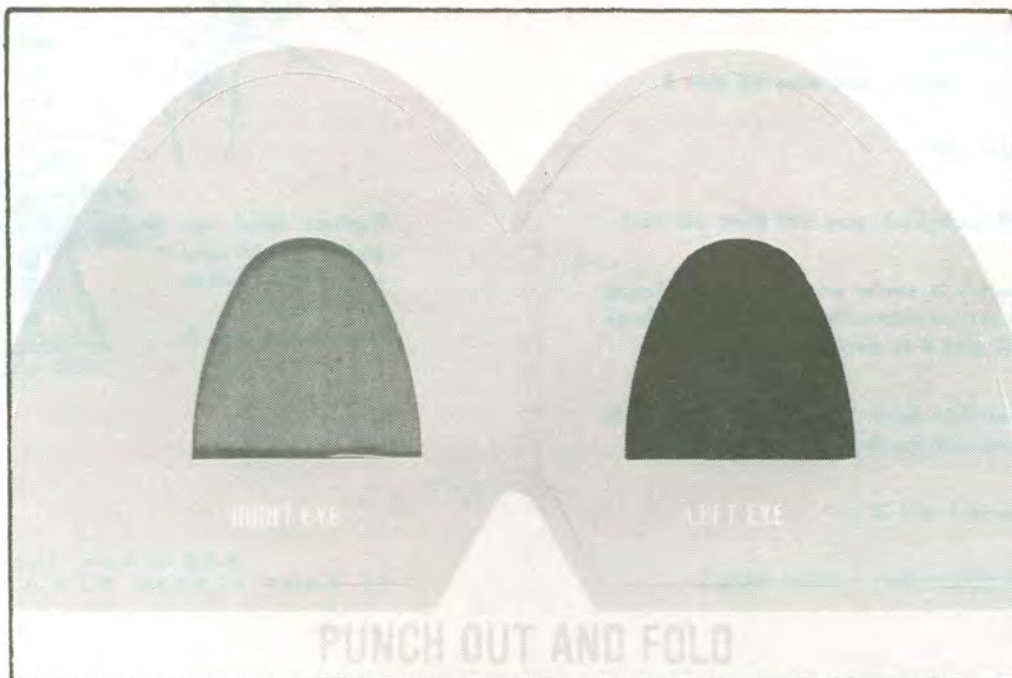



**BOXING MATCH**

**CAN YOU NAME THEM?**

LOCOMOTION ANSWERS: 6. NOTHING IT JUST WAVED. 7. WHEN IT HUGS THE SHORE. 8. THROUGH THEIR ENGINEERS. 9. A CHEW CHEW TRAIN. 10. A STEWPIRIVER.

DARREN, DANER, FRANKEN, VIXEN, COMET, CUPID, DONNER, BLITZEN AND NODDLEN.

**MCDONALD'S**

**3.0 HAPPY MEAL**

presents

**LAUGHINGSTOCK**

1. WHERE DO COWS GO ON SATURDAY NIGHT?

2. WHAT SHOULD YOU PLANT TO MAKE MONEY?

CLARE!

3. WHAT'S A CROSS BETWEEN A DOG AND A CHICKEN?

4. HOW DO YOU KEEP A TURKEY IN SUSPENSE?

5. WHERE DOES A SHEEP GET HIS HAIR CUT?

©1981 M. Donald's Corporation

**TURKEY DINNER**

**WHAT IS IT?**

LAUGHINGSTOCK ANSWERS: 1. TO THE MOO-VIES. 2. MINT. 3. A POOCHED EGG. 4. I'LL TELL YOU TOMORROW. 5. AT THE GAA-BAR SHOP.

TWO BIRDS PULLING AT A WORM.

**MCDONALD'S**

**3.0 HAPPY MEAL**

presents

**LOCOMOTION**

6. WHAT DID THE OCEAN SAY WHEN THE PLANE FLEW OVER?

7. WHEN DOES A BOAT SHOW AFFECTION?

8. HOW DO TRAINS HEAR?

9. WHAT KIND OF TRAIN CHEWS BUBBLEGUM?

10. WHAT KIND OF DRIVER NEVER GETS ARRESTED?



# ELECTRONIC MAN COSTUME

CARDBOARD TOY DREAMS

by Steve Powers

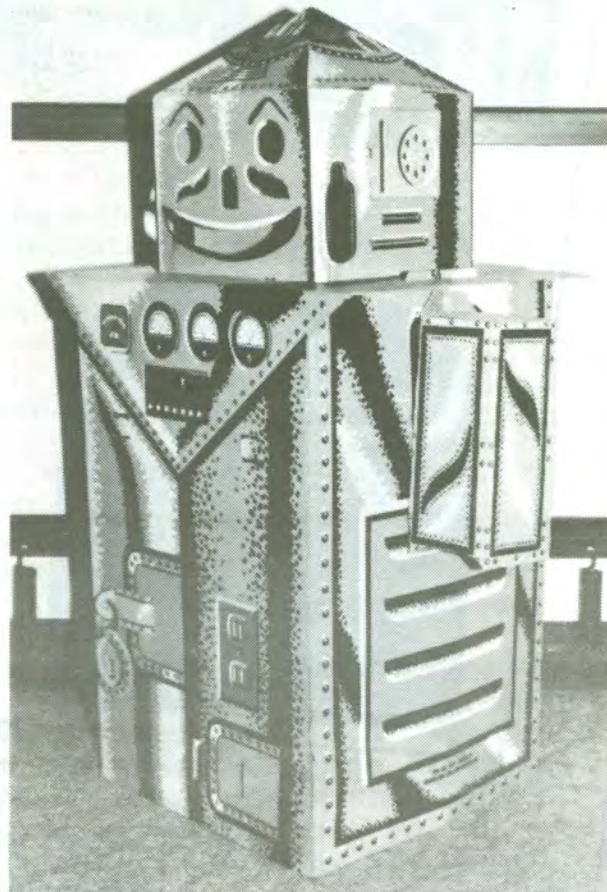

I guess there was a time when you couldn't get a cheaper toy than one made out of cardboard! (I mean, what did it cost to produce something like this in the 1950's?!) Er, excuse me, did I say cardboard? I meant to say fibreboard. 20 to 30 years ago someone figured out they could sell toys made out of "fibreboard" figuring that little kids who read comic books wouldn't know what that is. After all, you put stuff in a cardboard box or slid down grassy slopes in one. Who's mom or dad ever said, "Son, go get me a fibreboard box out of the garage"? No, we comic book readers probably thought "sturdily constructed 200 lb. test fibreboard" was something like insurance guys crashed cars into to see how badly their test cars got crunched. Say it slowly out loud: F I B R E B O A R D. Sounds a lot more sturdy than cardboard!

Old toys made out of cardboard are difficult to come by for obvious reasons. Face it. Kids like to destroy things. Can you imagine the fun of setting up the Electronic Man Costume and jumping on it feet first or using it for sling shot practice? Plus given a little dampness or age, these things fall to pieces. That's why I couldn't pass up this cardboard costume when one came along, mint and in the original box with instructions no less. Well, that's one of the reasons. The main one is coming up.

To look more closely at this toy first, it was manufactured by Fibre-Bilt Toys, a division of the Long Island Container Corp., Long Island City, New York. Like the rocket on the PEZ Space Gun, the red and blue graphics on the box are vintage 1950's. The box measures 25½" x 20½". When fully assembled the costume measures approximately 3' high. As you can see from the box picture, the child is fully covered by the costume except for the forearms and legs. There are straps inside to balance it on the shoulders. Its colors are black,



## CARDBOARD TOY DREAMS

white, gray, and green. The dome graphics on the peak of the head are a real combination of 1950's naiveté - part radio tubes, part atomic energy! There is also an electrical socket and an "on and off" switch.

I can't imagine this outfit lasting 5 minutes if I had worn it to a cub scout costume party when I was a boy with all the running and pushing! Someone took really good care of this get-up, or maybe didn't want to be caught dead in it and so never wore it!

Now on to my story. While I haven't yet seen an ad for Fibre-Bilt's Electronic Man, I have seen a few ads in 1950's and 60's comic books of other "fibreboard" toys such as "a real mobile tank" which was over 6 feet long. Large enough for two kids, it had features such as an intercom system, revolving turret, elevating 75MM cannon, co-axial machine gun, range-finder sight for pin-pointing targets, real periscope, 2 way radio controls, a whip antenna and a flag. This "authentic replica of the mighty General Patton tank", this "six foot hunk of equipment" cost only \$4.98! And about the shipping charges the poor folks at "Honor House" Products Corp. of Lynbrook, New York put it this way: "Because of its gigantic size, we are forced to ask for an additional .63¢ shipping charges." (emphasis mine.)

The picture to the right shows something similar to the "real mobile tank". It was THE toy of my dreams when I was a little boy - The POLARIS NUCLEAR SUB! I have never forgot the ad associated with this toy, probably because I used to stare at it and read it over and over again. Most of the time that was in a "fort" two little second grade chums and I built into the side of a hill by covering a gully with a couple of old sheets of plywood. We called it "the Viking Club", I think inspired by a book that was read to us in class. We made shields and swords and wrote the name of our club on our t-shirts and jackets. I distinctly remember looking at THE AD for the Polaris Nuclear Sub time and time again in our fort, dreaming of the day I could afford one. (I guess I must have thought that \$6.98 plus .75¢ shipping was unattainable, even if I rounded up every deposit bottle I could find!) I would point it out to my fellow Vikings and tell them how great it would be to have our own sub. You see, I believed with all my heart that we would be able to take it down to the beach or the lake and actually go underwater! That's right - look what the ad said:



**FEATURES**

- Over 7 feet long
- Seats 2 kids
- Controls that work
- Rockets that fire
- Real periscope
- Firing torpedoes
- Electrically lit instrument panel

How proud you will be as commander of your own POLARIS SUB — the most powerful weapon in the world! What hours of imaginative play and fun as you and your friends dive, surface, maneuver, watch the enemy through the periscope and fire your nuclear missiles and torpedoes! What thrills as you play at hunting sunken treasures in pirate waters and exploring the strange and mysterious bottom of the deep ocean floor!

**HOURS AND HOURS OF ADVENTURE**  
Sturdily constructed of 200 lb. test fibreboard. Comes complete with easy assembly instructions. Costs only \$6.98 for this giant of fun, adventure and science. (Because of the POLARIS SUB's giant size we must ask for 75c shipping charges.)

**MONEY BACK GUARANTEE**  
Order today and we will rush your POLARIS NUCLEAR SUB to you. Use it for 10 full days. If you don't think it is the greatest ever—the best toy you ever had—just send it back for full purchase price refund.

**10 DAY FREE TRIAL**

**HONOR HOUSE PROD. CO. DEPT. 77PS92  
LYNBROOK, NEW YORK**

Rush me my POLARIS NUCLEAR SUB. I can use it for 10 days and if I am not delighted return it for full purchase price refund.

SEND IT PREPAID. I enclose \$6.98 plus 75c to help cover shipping charges.

SEND IT C.O.D. I enclose \$1.00 good-will deposit and I will pay postman \$5.98 on delivery plus C.O.D. postage.

NAME \_\_\_\_\_

ADDRESS \_\_\_\_\_

CITY \_\_\_\_\_ ZONE \_\_\_\_\_ STATE \_\_\_\_\_

N.Y. State residents please add 14¢ sales tax.



## CARDBOARD TOY DREAMS

One little word I failed to pick up or understand in the ad about this unbelievably great toy was in the fact that it said, "What hours or imaginative play and fun . . . ". Why, I could have taken that to mean that by using your imagination you'll be able to think of great uses for it! Besides, it was made out of 200 lb. test fibreboard!

Well, Honor House Prod. Co. must have sold a ton of cardboard submarines to little boys and girls who thought it really went underwater like me. In fact, I think ads like this may no longer be legal because of little words like "imaginative" that are barely slipped in.

I never got a Polaris Nuclear Sub from Honor House, but there is enough of that little boy still left in me that I still want one, even if it doesn't go underwater! I guess I'm prejudiced on this point, but it still looks like one of the greatest toys ever made (if you're wearing rose colored glasses like me). And maybe if I played at the control panel with my son, we just might think for a moment that we were "hunting sunken treasures in pirate waters and exploring the strange and mysterious bottom of the deep ocean floor!"

If anyone out there can help us find one, you'll be helping me realize a dream of more than 20 years ago.

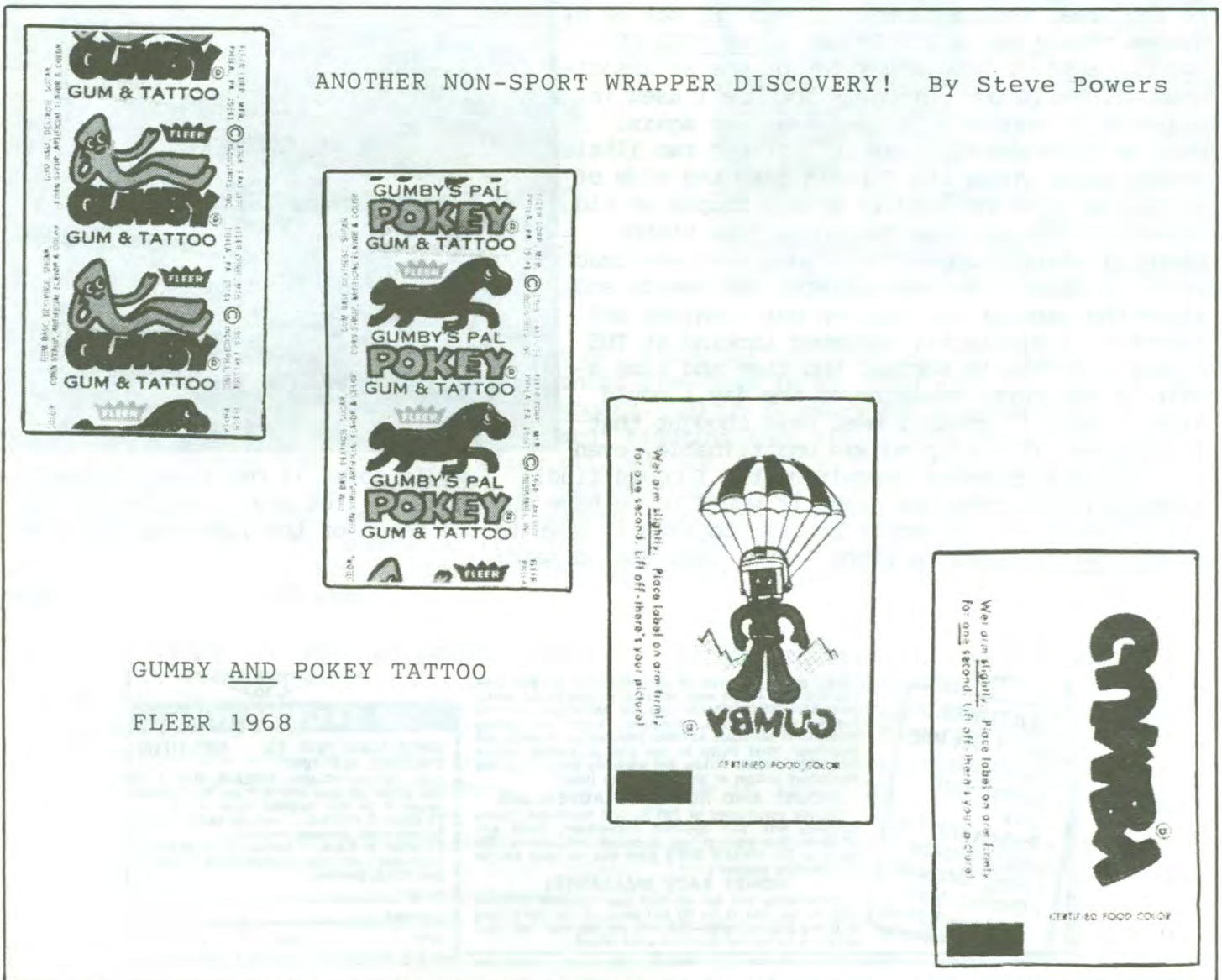



# DATING YOUR PEZ PART 2

By Maryann Kennedy  
409 N. 5th Street  
Marshall, MN 56258

Hi PEZ collectors - some more on PEZ patents. Steve brought up an interesting point about 1st Series PEZ being purchased in the 1970's. In issue #1 he also stated that the inner head mechanism in early 1st Series was different than the mechanism in later 1st Series.

Several examples of mismatched dispensers and patent numbers that I have are: Cool Cat, both 1st Series and 2nd Series. Both are marked on the heads, "Warner Bros. Inc. 1980"; I also have a Pony - 1st Series - purchased new in 1985. This is the one I mentioned before in the first "Dating Your PEZ" article, with a red "New Dispenser" sticker on the blister pack.

This mismatch seems to occur mostly with one Austrian manufacturer. I doubt they still have old inventory left, but I believe they are still making some plastic outer shells with 1st Series patent numbers. This manufacturer also makes 4th Series dispensers. Maybe one of their machines still has an old patent number plate that they either haven't bothered to change or haven't even noticed. The fact that the head mechanisms are different in early and late 1st Series dispensers seems to reinforce that idea. New mechanism, new plastic outer dispenser, old patent number. What do you think?

This brings up the point then that the patent numbers alone cannot accurately date our PEZ dispensers for us. That would be too easy anyway, right?

## TRUCKS!

By Judy Wehner  
326 W. 113th Ave.  
Crown Point, IN  
46307

My husband is in the excavating business and our boys have always collected trucks and earth-moving equipment. So if you can't fight them - join them. So here are my trucks!

Campbell's truck is an 18½" Ertl truck offered in 1985. Peter Pan, Smucker's, Rath, and Dolly Madison trucks are 21" 18 wheelers made by Nylint.

Hershey's offered a 9" 18 wheeler by Winross in 1985. It was \$24.95 - maybe that is why I don't have it.

There are more advertising trucks made by Winross and other companies that were not premiums. The five trucks I have mentioned were obtained through the company they advertise.

The Premium Watch will be very helpful for trucks. I just happened to turn Rath Bacon over and found the offer. There are probably many more I'm not aware of.





# PREMIUM

# WATCH

Thanks to all the "premium watchers" across the U.S. and Canada who have contributed to this issue's listing! The more response from our readers, the bigger Premium Watch will become. If you have not been able to find a particular premium notice or "specially marked package" we suggest you call or write the companies as they are usually very helpful and respond quickly. When all else fails send The Old Variety Store a self addressed stamped envelope and .15¢ per premium notice and we will make and send you a photo copy if we have the original or some type of information. If you desire to send us new premium information for Premium Watch but need to keep your original notice, we welcome photo copies or hand written information.

Almost all premium offers today are available from the companies by mail only. We designate "FI" as "Free Inside" when the premium is inside or part of the packaging.

Chef Boyardee Tic Tac Toe's  
TYCO Super Block Train Set

Fruit Corners Fruit Roll-Ups  
Play - Doh

Kool - Aid  
4 Smiling Mugs & 1 Pitcher  
Crayola Coloring Markers (in blister pack) Comic Book

Life Cereal  
Life Summer Gear: Cap, Watch, Sunglasses, Volleyball, Towel, Shorts

Post Natural Bran Flakes  
Readers Digest Book

Post Grape Nuts Flakes  
Sport Outdoor Accessories

Post Fruity Pebbles  
Fred, Barney, or Dino Eraser FI

Post Cocoa Pebbles  
Private Eye Glasses

Post Honey Comb  
Magic Pencil FI

Wheaties  
"Save \$20.00 on Converse Tennis Shoes"

Grape Nuts Cereal  
Nature Poster

Cheerios Cereal  
Special Pencil

Tasteeos/ Corn Flakes Cereal  
Dinosaur Cut-out On Box Backs

Corn Flakes/Frosted Mini-Wheats  
Cereal Flavor Lock

Apple Jacks Cereal  
Whistling Pop FI

Fruit Rings Cereal  
Young Astronaut Program Offer FI

Frosted Flakes Cereal  
Garfield Bike Reflector FI

Nutri Grain Cereal  
Roses

Nutrific Cereal  
Health Passport FI

Honey Graham Chex Cereal  
Stunt Plane FI

Cheerios Cereal  
"Star Trek - The Next Generation" - 1 of 6 stickers FI, Poster

Chef Boyardee Spaghetti & Meat Balls  
Autographed Wilson Baseball  
Pencil Box

Swiss Miss Hot Cocoa Mix/Pudding Paks  
Swiss Miss 13½ Cloth Doll

Mr. Bubble Bubble Bath  
Mr. Bubble T-Shirt, Sweatshirt, Nite Light, Watch, Bath Towel

Del Monte Fruit Snacks  
California Raisin Figures on Musical Stage (plays 15 seconds of "I Heard It Through The Grapevine!") plus custom mini-lunchbox/storage case

Del Monte Products  
Canister Set

Eckrich Smoked Sausage  
Cardboard Clubhouse

Snuggle Fabric Softener  
Snuggle Bear Hug - 3" Bear & Personalized Message Card

Leaf Candy  
Special Olympics Contribution/Sports Equipment/Collector's Series Baseball "Hall of Famer" Cards

Oscar Mayer Products  
Baseball Equipment

Little Debbie Snack Foods  
Little Debbie Poster Board Doll House and Paper Doll

Nestle's Quik  
Fun Club Kit

Bold 3 Detergent  
Poster/Calender "of your favorite (male) soap opera star"

Fritos Corn Chips  
Cooler Chair



P R E M I U M   W A T C H

Almond Delight Cereal  
Free Utilities Check or Utilities Saving Ideas FI

Meow Mix Cat Food  
Meow Mix Canister

Post Cereals  
Cali Quail 8" Plush Toy

Dole Pineapple Products  
Cooking with Kenny Rogers Cookbook

Aqua-Fresh Toothpaste  
Back to School Lunch Kit

TANG Breakfast Beverage Crystals  
"Fun Gifts": #1 Phone, AM/FM Radio, T-Shirt, Suspender, Pocketlight, Pocket Watch, Headband, Sweatbands, Sunglasses, Taste Stickers, Soft Foam Basketball & Hoop, Laser Challenge

Surf Laundry Detergent  
Topps Baseball Card Book

Star-Kist Tuna  
Charlie's Recipe Booklet

Starburst Fruit Chews & Skittles Bite Size Candies  
Candy Crusin' T-Shirt

Cap'n Crunch's Crunch Berries Cereal  
Glow in the Dark Moon Globe or Crunch World Globe or Golden Globe with Official Prize Claim worth \$50.00. (Note: There are only 1,000 Golden Globes making this premium already rare. The first O.V.S. reader who sends in a color picture of his or hers Golden Globe and \$50.00 Official Prize Claim Form will win from us a FREE one year subscription! Offer good only 60 days from this issue date.) FI: Cap'n Crunch Adventure Catalog which lists these mail away for premiums: Cap'n Crunch 14" Plush Toy, Treasure Chest, Island Adventure Game, and Digital Watch.

Fancy Feast Gourmet Cat Food  
Fancy Feast Crystal Goblet (That's right. A premium for cats! -ed.)

Betty Crocker  
Circus Time 3-Piece Dinnerware Set; Care Bears 3-Piece Dinnerware Set; Peter Rabbit 3-Piece Dinnerware Set; Care Bears 3-Piece Child's Stainless Set; Peter Rabbit 2-Piece Baby Educator Stainless Set

Polly - O String Cheese  
Polly - O Back Pack

Dow Bathroom Cleaner  
Scrubbing Bubble 1988 Calendar

Mrs. Butterworth's Syrup  
Mrs. Butterworth's "What to Do When" Kit (for latch key kids! -ed.)

Promise Margerine  
Promise Hear Smart Calculator  
"Promise wants to exceed its goal of donating \$125,000 to the American Heart Association"

Pampers Diapers  
Pampers Playwear T-Shirt

Kimberly - Clark Products  
45 Minute Aerobic Exercise Tape  
"For every exercise tape requested Kimberly - Clark will donate .50¢ to the American Heart Association"

Campbell's Soup  
1987 Campbell Kids Ornament or 1988 Campbell Kids Calendar

Quaker Chewy Granola Bars  
33 Quaker/Topps Baseball Super Star Cards FI. Complete Set or Official Topps Baseball Stickers and Yearbook Starter Kit

Gatorade Drink  
30 Day Health Club Membership Offer or "inside Sports" 3 Months Magazine Subscription or Gatorade Squeeze Bottle

Golden Griddle Syrup  
Muppet Babies Breakfast Set

9 Lives Cat Food  
Morris Calendar

Jiffy Pop Pop Corn  
Dollar Back On Your Next Video Rental Certificate FI

Scott Paper Products  
"Learning Tools for Schools" Seals - good toward free school educational equipment FI

Pillsbury Toaster Strudel/Toaster Muffins/Microwave Pancakes  
Doughboy Watch

Johnson Wax Products  
Remote Control Robot

Pillsbury Flour  
Poppin Fresh Ceramic Bank

Cadbury's Chocolate  
4 3/4" Wedgewood Plate

Meaty Bone Dog Biscuits  
Lifetime Petfinders Membership

Mighty Dog Dog Food  
Mighty Dog Calendar

Lowrey's Beef Jerky  
Howard the Coward Watch

McDonald's  
McDonald's & KRON TV (San Francisco) "Plan To Get Out Alive" Fire Booklet FI; The Real Ghostbusters Happy Meals with School Supplies FI

Keebler Cookies  
21" Steel Toy Truck (with Ernie and Elves on Side); Ernie TELphone

Armour Hot Dogs  
Superman 50th Anniversary Watch

Everready Batteries  
Compact Light

Jello Gelatin Pops  
Legos

Aunt Jemima  
Puffalumps



P R E M I U M   W A T C H

Bugs Bunny Vitamins  
Bugs Bunny Figure

Sugar Golden Crisp Cereal  
3-D Viewer FI

Skoal Bandits Chewing Tobacco  
Auto Racing Lithograph

Reese's Pieces/Nibs Cheery Bits/Twizzlers Strawberry Twists Candy Maxwell UR90 Blank Audio Cassette Tape

Real California Cheese  
Cow Apron, Cow T-Shirt, Cow Tablewear (ceramic milk carton, etc.), Cow Watch, Toy Calf (have a cow. - ed.)

Woolite/Woolite Spot & Rug Cleaners/Easy Off Oven Cleaner/PAM Cooking Spray Donating coupon value to help raise \$200,000 for U.S. Marine Corps Toys for Tots campaign for needy children this Christmas

Chef Boyardee Products  
Corning Limited Edition Microwave Bowl

Coronet Paper Products  
Bachman 73-Piece HO Electric Train Set with Customized Coronet Box Car

Crisco/Duncan Hines Products  
Fisher Price Fun With Food Gift Set

Hershey's Golden Almond Solitaires

Hershey's 11 oz. Golden Almond Solitaires Candy Porcelain Candy Dish

Cascade Dishwashing Detergent/Tide Laundry Detergent/Dawn Dishwashing Detergent Fisher Price Fun Starters Toys

Wendy's Kid's Meal  
Teddy Ruxpin Box and Cup FI  
Teddy Ruxpin & Friends Place Mat Set

Uncle Ben's Country Inn Rice/Arm & Hammer Carpet and Room Deodorizer/Bama Jam, Jelly or Preserves  
Special Edition Baby Jammie Pies Doll

Airwick Products  
24" x 36" Plush Bear Rug

General Mills Fruit Roll Ups  
Play Doh

Sanka Decaffeinated Coffee  
1988 Sanka Calendar and Catalog

Tang  
Tang Soccer Team Membership: Pelé poster, membership card, iron on patch, Pelé's best soccer tips, Spalding soccer catalog

Dole Bananas  
4 Different 10" Plush Bananimals

Flavor Tree Fruit Bears & Fruit Circus Snacks 3 Different Watches

Fab, Fresh Start or Dynamo Laundry Detergent/Palmolive Automatic Dishwasher Detergent, Dishwashing Liquid, Soap Kick Off For Kids Jersey. These products are sponsoring the following charities: Boys Clubs, Girls Clubs, The Vincent T. Lombardi Cancer Foundation.

Popeye's Famous Fried Chicken & Biscuits Pal Pak Meal with Balloon

Colgate Toothpaste with Tarter Control 57" U.S.S. Colgate Inflatable Boat

Jerky Treats Dog Snacks  
Jerky Treats/Norman Rockwell Canister

Fruit-Fresh Fruit Protector  
Betty Crocker Peach Pie Kitchen Ensemble (dish cloth, potholder, oven mitt, and kitchen towel)

Jeno's Pizza Rolls  
NFL Team Poster (all 38 teams available)

Lipton Rice & Sauce/Potatoes & Sauce/Noodles & Sauce/Cool Side Salads  
Lipton Side Dish 1988 Calendar

Progresso Products  
Progresso's A Taste of Italy Cookbook

Puppy Chow Puppy Food  
Puppy Bowl

Star Kist Tuna  
Charlie the Tuna Telephone

Friskies/Chef's Blend Cat Food  
Friskies Plush Pet

Uranus Strikes! Trading Cards  
Randomly inserted coupons good for free Uranus Strikes! premiums

Cracker Jack  
Cracker Jack Kid Club

Planters Original Peanut Bar  
Sports Nut Trivia Game

Betty Crocker Tuna Helper/Hamburger-Helper Helping Hand Radio MAF

Colgate Toothpaste  
Disney Pencil Pouch (free in stores)

Colgate Toothpaste/Tarter Control  
U.S.S. Colgate 57" Inflatable Boat

Happy Cat Moist Cat Food  
Happy Cat Watch & Christmas Stocking

Hershey's Syrup  
Ice Cream Scoop

Lender's Bagels  
Mug

Klondike Ice Cream Bars  
Plush Klondike 10" & 5" Huggin' Bears

Cheetos  
Chester Cheetah Glassware

Honey Nut Cheerios Cereal  
Personalized Pad

Cocoa Puffs Cereal  
Water Monster

Trix Cereal  
Trix Bubble Gum FI

Ice Cream Cones Cereal  
Mini Piano

Fruit Loops/Honey Smacks/Corn Pops Cereal Dinosaur Marker FI



## THE OLD VARIETY STORE MAIL ORDER



Please add \$2.00 postage and handling per item. If you purchase many items and the postage isn't as much per item, we will refund your portion of extra postage cost. California residents must add 6½ % sales tax. If you need to talk to Steve he can usually be reached in the evening between 6 p.m. and 9 p.m. Pacific Time or possibly on weekends.

Steve Powers  
121 Codo St.  
Moss Beach, CA 94038  
(415) 728-5851

- 1942 Sunbeam Doughnuts Box. Colorful. Pictures Miss Sunbeam and package of Sunbeam Bread is advertised underneath. Cellophane window torn, otherwise quite nice. \$6.00
- Nestle Hot Cocoa Mix Bank. Pictures a bank and chocolate coins on front and back. \$5.00
- Safeway/Bel-air Apple Juice Can Bank. Looks just like the real thing. \$4.00
- Wells Fargo. Impressive, beautifully detailed and painted plastic Wells Fargo & Co. Express western building bank. Says underneath: "Exclusively for Wells Fargo Bank". 6½" tall on a 5½" base. \$18.00
- 1933 Ovaltine/Radio Premium. "Little Orphan Annie's Treasure Hunt" board game. I have seen one of these games with the paper playing pieces for sale at \$125.00. This game does not have the paper pieces but is really nice and only \$30.00!
- Mr. Peanut full color magazine ad from the early 50's. Pictures 7 different premiums including the Presidents of the U.S. Paint Book. (see below) \$8.00
- Mr. Peanut 1953 Presidents of the United States of America Point Book. Only one president colored and done well. Contains a great Planters Peanuts center fold ad. \$20.00
- Same as above but with different cover and copyright 1960. Different center fold entitled "Democracy in Action". \$20.00
- Mr. Peanut 1950 Seeing the U.S.A. Paint Book. For some reason the Planters Peanuts center fold ad is sealed closed with tape and perhaps some glue. \$18.00
- Jack in the Box "Shake Hans" miniature bendable figure. \$3.00
- Bob's Big Boy vinyl figure bank. 1973. \$7.00
- "The Magical Burger King" 1980 20" play figure in original box. Near mint condition, missing child's ring and figure's ring label. With disappearing Hamburger and Scarf tricks. \$18.00
- Pillsbury Doughboy 7" vinyl figure. 1971. \$5.00
- Hawaiian Punch 2½" hard blue plastic "Punchy" figure. 1978. \$4.00
- Sweetheart's Paper Drinking Straws. "Mother Goose" Colorful with nursery rhyme pictures. \$15.00
- Ovaltine/Capt. Midnight 1950's redplastic cup with colorful decals. No top. \$15.00
- Beany & Cecil yellow plastic cup. Colorful decal pictures "Wong, Cecil, and Dishonest John". Premium? \$15.00
- 7-Up Truck. Tin litho, made in Japan. Played with, but bright litho's of 7-Up and old slogan. \$25.00
- Borden's "Elsie's Treasure Chest of Lovely Premiums". 14 page booklet, 1949. \$12.00
- Gold Medal Flour premiums - 2 puzzles in original mailing envelope. "Famous American Landmarks" and "U.S.A. Map" (missing one piece). Both for \$10.00
- Mason's Root Beer vacuform sign. 11½" x 12" with Mason's Root Beer bottle on the design. One half of bottle cap missing with a couple of near invisible cracks. From a soda fountain or diner. Attractive. \$15.00
- Gaylord Perry Peanut Farm 5 lb. burlap sack. Pictures the famous pitcher and tractor. Mint, no peanuts. \$10.00
- Señor Pico 1966 plastic swizzle stick. \$5.00
- Colgate-Palmolive Super Suds box back and side panel featuring un-cut Circus Town Toys. 1928. \$10.00
- Kellogg's premium probably from the Depression. 4 Corn Flakes recipes in envelope, one of which is "Corn Flake Cream Dessert". Yum. \$6.00
- Superman Cake Decoration Set. Mint, old store stock from 1978. Flying Superman and deco-ish buildings including The Daily Planet which can hold candles. \$3.50
- Potato Gun. Yep, unusual. Push barrel into potato, pull it out, and shoot the potato piece. \$5.00
- Marx 9-piece plastic bedroom furniture set mint in blister pack. \$20.00
- Candy Box "Smiles Assorted Chews". Mint, never used. Colorful clown picture. Delight Sweets, Inc. \$4.00
- "McCallum". Highly unusual David "The Man from U.N.C.L.E." McCallum instrumental record from the 60's. The word "FREE" is stamped through upper right corner. \$12.00
- "Music from Bonanza and The High Chaparral". 2 record set pictures both casts. Performed by Xanadu Pleasure Dome. \$10.00
- Occupied Japan 3" strange looking under water fish tank man. Occupied is spelled "occupiep"! \$15.00



Buy, Sell, Trade & Make Friends In

# THE TREE HOUSE

WANTED

Wanted: McDonald's items, Kool Aid items, PEZ holders & displays, old cereal premiums, & candy store small oak display cases. Top prices paid. Send lists and prices to:

Craig Robbins  
22262 Craggy View  
Chatsworth, CA 91311

Wanted: McDonald's 3-D Happy Meals, 7-11 convenience store 3-D cards, and other 3-D items. Anaglyph (red/green) only, no view-master or stereo. Serious buyer.

Greg Anglin  
7410 Farmstead Rd.  
Liverpool, N.Y. 13088

Wanted - Wonder Bread and Hostess Cake memorabilia including packaging, signs, advertising, etc. Write:

E. Piper  
209 Monaco Dr.  
Santa Ana, CA 92703

WANTED: Older PEZ Dispensers: Tinkerbell, Eerie Specters, Engineer w/Beard, Ringmaster, Die-cuts, Circus Elephant, Pear, Pineapple, Apple, Lemon, etc. PEZ PREMIUMS: Flashlight, Camera, Stands, Hulk Mask, Clickers, 50's Space Gun, etc. . . PEZ ADVERTISING. ANYTHING PEZ. Will buy or trade. I'd love to hear from all you PEZ collectors that read this. It is so much fun to share and exchange information, so drop me a line. All letters answered.

Maryann Kennedy  
409 N. 5th Street  
Marshall, MN 56258  
(507) 532-6926

Wanted - McDonald's Kermit on skateboard; Fozie with horse for trade. PEZ dispensers, some for trade; will pay, send price, description.

Karen Lynn  
5731 N. Harvard  
Portland, OR 97203

WANTED

BATMAN COLLECTIBLES WANTED. Peanut butter jars, milk bottle lids, 1966 Kellogg's cereal boxes, 1970's cereal boxes and more. Batman stuff for trade too.

Joe Desris, #107  
1202-60th Street  
Kenosha, WI 53140

WANTED: Any/all Advertising Premium Characters! Green Giant, Dough Boy, Colonel Sanders, Charlie Tuna, etc. Good - Mint Condition. Send to:

Bob Ting  
3301 Bay Court  
Belmont, CA 94002

Wanted: Super Hero premium, Fan Club item from Marvel or DC. Also will swop my current Kellogg's for Cap'n Crunch premiums.

Charles Kline  
P. O. Box 791  
Cleveland, MS 38732

FOR SALE

FOR SALE OR TRADE: Dick Tracy & Mighty Mouse plastic soaky bottles, 1960 plastic "Have Gun Will Travel" ring, 1960 Wheat Hearts premium "Mr. Peabody & Sherman" flicker square, 1958 Plastic Zorro Hat & Mask, 1966 Green Hornet Playing Cards. Will trade for or buy the following PEZ dispensers: Wolfman, Bozo, Green Hornet, Soft Heads, Thor. Write or call:

Norm Hunt  
38 Ward St.  
Clifton, N.J. 07011  
(201) 779-3567

For Sale: Post Cereal Circus Cards (1947). Three different, unpunched! Dancing clown, merry-go-round, cycling sam. Rare, early cereal premiums, \$8.00 each. Red Hots in original 1950's glass container, still sealed. \$9.00. Mickey Mouse Disney Cookies box, slight damage. \$3.00. Postage \$1.00.

Greg Anglin  
7410 Farmstead Rd.  
Liverpool, N.Y. 13088





Subscription Rate: \$15.00 for one year - six bi-monthly issues. Sample copy: First issue - \$4.00. Current - \$3.00. **FREE** 30 word ad with all subscriptions.

Classified Advertising in the Tree House: .05¢ per word; .10¢ per underlined word; .15¢ per **BOLD PRINT** word. \$1.00 minimum.

<u>Display Advertising Rates:</u>	(Camera Ready, Pre-typed)	(Hand Written, Rough Copy)
1/6 Page (2½"W X 5"H)	\$7.00	\$10.00
1/4 Page (4"W X 5"H)	\$12.00	\$15.00
1/2 Page (8"W X 5"H <u>or</u> 4"W X 10"H)	\$25.00	\$30.00
Full Page (8"W X 10"H)	\$50.00	\$60.00

Advertising Deadlines: Oct. 1 for October 15 issue  
Dec. 1 for December 15 issue  
Feb. 1 for February 15 issue  
April 1 for April 15 issue  
June 1 for June 15 issue  
Aug. 1 for August 15 issue

**FREE 100 WORD** classified ad or 1/6 page display ad if you submit an article and it is printed.

Questions or comments? Yours are welcome. Please enclose a self addressed stamped envelope if you need a reply. Best time to call on weekdays is between 6:00 and 9:00 p.m. Pacific Time.

**Make checks payable to:** Powers Media, 121 Codo St., Moss Beach, CA 94038

The Old Variety Store is published bi-monthly by Powers Media, Stephen Powers, editor and owner, 121 Codo St., Moss Beach, CA 94038. Telephone number (415) 728-5851. Copyright 1987 Powers Media, all rights reserved. No part of this publication may be printed without the expressed written permission of the publisher. Article rights remain with the authors. Powers Media reserves the right to edit or reject any ad. Powers Media does not guarantee any advertisers claims. Articles printed are the opinions of the authors and may not necessarily be the same as the publisher.





RED AND BLACK 1950's PEZ SPACE GUNS

THE OLD VARIETY STORE  
121 CODO ST., MOSS BEACH, CA 94038

THE INSIDE SCOOP

- 1 NEWS FROM THE STOREKEEPER
- 2 LETTERS
- 4 KID'S CORNER
- 5 GETAWAY CHASE GAME
- 7 HALLOWEEN CANDY CONTAINERS
- 8 IT GAME FROM PEZ SPACE HEADQUARTERS!
- 11 McDONALD'S 3-D HAPPY MEAL
- 13 ELECTRONIC MAN & CARDBOARD TOY DREAMS
- 15 GUMBY & POKEY WRAPPERS
- 16 TRUCKS!
- 16 DATING YOUR PEZ PART 2
- 17 PREMIUM WATCH
- 21 THE TREE HOUSE CLASSIFIED ADVERTISING

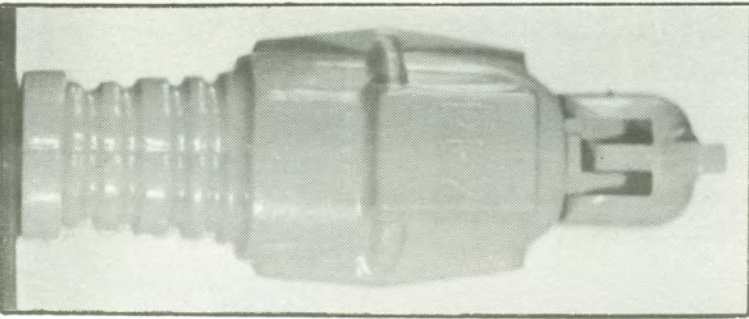

REAR-VIEW ROBOT!

FIRST CLASS TO: